

MODEL USN1616L

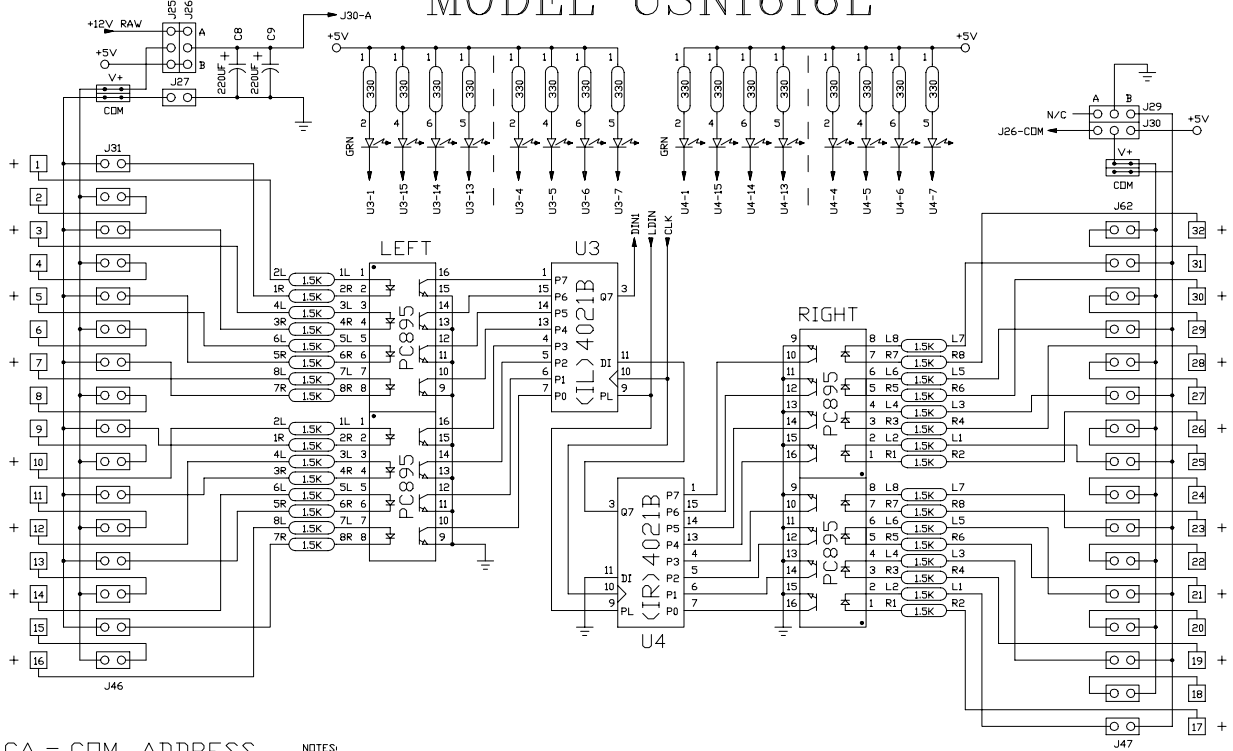

CA = COM. ADDRESS
 ID = CONFIGURATION
 OL = OUTPUT LEFT
 OR = OUTPUT RIGHT
 IL = INPUT LEFT
 IR = INPUT RIGHT

NOTES:

- 1) MIN ISOLATED INPUT CURRENT = 1.2MA
- 2) MIN CURRENT TRANSFER RATIO = 20%
- 3) MAX. POWER (2 RESISTORS) = 0.25W
- 4) R = 6800 X 2, 18-60V, 1.2-4.5MA
- 5) R = 5100 X 2, 13-51V, 1.2-5.0MA
- 6) R = 4700 X 2, 12-48V, 1.2-5.1MA
- 7) R = 3300 X 2, 9-40V, 1.2-6.1MA
- 8) R = 2200 X 2, 7-32V, 1.2-7.3MA*(STD.)
- 9) R = 1500 X 2, 5-27V, 1.2-9.0MA
- 10) R = 1000 X 2, 3.8-22V, 1.2-11.0MA

This drawing is the property of R. E. SMITH and shall not be used except with the written permission of R. E. SMITH; no copies shall be made of it and all proprietary rights in the matter contained in this drawing are the property of R. E. SMITH. COPYRIGHT - R. E. SMITH, 1994	DRAWN BY RES	SUBJECT 16-IN/16-OUT PCB	
	DATE 9-5-94	FDR INPUT SECTION	
	SCALE NONE	RES R. E. SMITH 480 FULFORDVILLE RD. HAMILTON, ONT. L8S 4S6	DWG. NO. 9404-10001
SHEET 1 OF 1	USN16161	CHKD BY RES	